



北京国电电科院检测科技有限公司
BEIJING GUODIAN NDT CO., LTD.

Smart Flashlight GD-3450



Feature:

- Telephone, Video&Audio, Lighting, Wifi/GPRS auto transmission video, Downloading APP, Patrol tour system etc.
- Professional platform to manage the video and photo.
- 1.54 inches HD display, Built-in processor of high frequency,
- The simple system platform combines real-time uploading of patrol and temperature data and multi-function task reminders.
- The industrial UI design, real-time synchronization with terminal and powerful cloud service strengthen management,
- High quality and performance, realize meticulous management and implementation of responsibility, and improve equipment utilization and labor efficiency.
- More than 20 languages are available.



Prism Lighting Services, LLC.



SPECIFICATION:

Light source: CREE 3WX2

Intensity:280 Lumen

Chip: 1.2Ghz dual core

Display size: 1.5inch

Display resolution: 480x240

Memory size: 4-32GB

Video format: AVI/3GP

Photo format: JPG/MPEG4

Video resolution: 1280x720

Photo resolution: 500 mp

Battery: 26650 li rechargeable batteries.

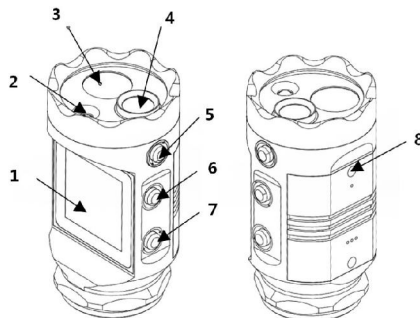



Prism Lighting Services, LLC.

1. Display
2. Fill light
3. Bright light
4. Camera
5. Strong light On/off button
6. Back button
7. Power button
8. Mounting holes of rear cover

Application:

GD-3450 is very good for Police, Security, Military, Railway, Mines, Sport, Electricity power, Gas, Oil, Machinery maintenance etc. to security, patrol, inspection.

Content:	1× Smart Flashlight	1×Rechargeable Li-Battery
	1×USB Cable	1×Charger
	1×8GB mini SD card	1×User Manual
	1×Neutral box	

